

# Hydrogen and oxygen isotopes of water from inclusions in minerals: design of a new crushing system and on-line continuous-flow isotope ratio mass spectrometric analysis

Yuri V. Dublyansky\* and Christoph Spötl

Institut für Geologie und Paläontologie, Leopold-Franzens-Universität, Innrain 52, 6020 Innsbruck, Austria

Received 7 April 2009; Revised 4 June 2009; Accepted 10 June 2009

**An analytical line for stable isotope analyses of water recovered from fluid inclusions in minerals was built and successfully tested. The line is based on the principle of continuous-flow analysis of water via high-temperature reduction on glassy carbon. It includes a custom-designed set of high-efficiency crushers and a cryo-focusing cell. This paper provides details of the line design and discusses strategies for line conditioning and mitigation of memory effects. The line allows measurements of hydrogen and oxygen isotopes during a single acquisition. The precision of the analyses depends on the amount of water released from the inclusions. The best results are obtained for samples containing at least 0.1–0.2  $\mu\text{L}$  (0.06–0.11  $\mu\text{mol}$ )  $\text{H}_2\text{O}$ . For such samples precision is better than 1.5‰ for  $\delta\text{D}$  and 0.5‰ for  $\delta^{18}\text{O}$  ( $1\sigma$ ). Smaller amounts of water can be measured but at lower precision. Analyses of modern calcite formed under stable conditions in a deep cave allowed assessment of the accuracy of the analyses. The  $\delta\text{D}$  values measured in fluid inclusions of this working standard match the  $\delta\text{D}$  value of the parent water, and the oxygen isotope values agree within ca. 0.5‰. This indicates that fluid inclusions trapped in calcite at near-ambient temperatures (e.g. speleothems and low-temperatures phreatic calcite) faithfully preserve the original isotopic composition of the parent waters. Copyright © 2009 John Wiley & Sons, Ltd.**

Fluid inclusions in minerals represent natural samples of water trapped at the time of mineral growth. The possibility of analyzing the stable isotope composition of these paleowaters has long been a tantalizing prospect for ore geologists, paleohydrogeologists, and, more recently, researchers studying the paleoclimate using speleothems. These carbonate deposits form in caves and determining the stable isotopic composition of their fluid-inclusion water provides a direct proxy of past precipitation, not unlike ice core.

Early mass spectrometric analyses of water extracted from speleothem samples were exclusively carried out using the dual-inlet method. The water was released from inclusions by coupling vacuum techniques with either thermal decrepitation or crushing/milling (see Dallai *et al.*<sup>1</sup> for an overview). The advent of continuous-flow isotope ratio mass spectrometry (CF-IRMS) allowed much faster analysis, avoiding time-consuming sample manipulations and off-line gas conversion steps. In a pioneering study, Sharp *et al.*<sup>2</sup> analyzed water transported by He flow and reacted with carbon at high temperature and suggested that this method

could be adopted for the analysis of fluid inclusions. The major advantage of this method is that hydrogen and oxygen isotopes can both be measured from the same, sub-microliter aliquot of water. Small but important technical modifications proposed by Gehre *et al.*<sup>3</sup> improved the precision of the CF-IRMS analysis, which now approaches dual-inlet precision.

Recently, Vonhof *et al.*<sup>4</sup> reported on a crushing device which, being installed along with a cryo-trap in a continuous-flow line, allowed the analysis of hydrogen and oxygen isotopes in fluid-inclusion waters. A first successful paleoclimatic application of this analytical line was reported by van Breukelen *et al.*<sup>5</sup> The design and development of a stable isotope line for fluid-inclusion analyses proceeded in parallel at Innsbruck University. The line was commissioned in 2007 and tested extensively during 2008. This paper provides a technical description of this setup and its performance.

In many geological applications, e.g. economic geology, mineralogy, and metamorphic petrology, the requirements with regard to precision of the isotope analyses of fluid-inclusion water are reasonably low. The key question addressed in these studies typically is the broad identification of the different sources of the mineral- or ore-forming fluids. A precision of several per mil ( $\delta\text{D}$ ) is typically sufficient to classify the paleofluid according to broad genetic categories, e.g., 'agmatic', 'metamorphic', or 'meteoric'. In

\*Correspondence to: Y. V. Dublyansky, Institut für Geologie und Paläontologie, Leopold-Franzens-Universität, Innrain 52, 6020 Innsbruck, Austria.

E-mail: Juri.Dublyansky@uibk.ac.at

Contract/grant sponsor: FWF; contract/grant number: 182070.

contrast, in paleohydrogeological and paleoclimate studies, information is commonly sought at both high resolution and high precision. The development of the fluid-inclusion analytical line at Innsbruck University therefore focused on optimizing precision and carefully evaluating accuracy.

## DESIGN OF THE LINE

### The line

The gross design of the line is similar to that proposed by Sharp *et al.*<sup>2</sup> and implemented by Vonhof *et al.*<sup>4</sup> Modifications mostly concern details of design of the line and its elements (Fig. 1). The carrier gas, He 6.0 (Messer Austria, Schwaz, Austria), is supplied to the line after passing through a high-capacity heated gas purifier (Supelco 2-3800; Sigma-Aldrich Handels GmbH, Vienna, Austria). The carrier gas enters the crusher, which is placed in an aluminum block heater employing two 60 W cartridge heaters (Watlow, Kronau, Germany). The temperature in the block (120°C) is controlled by an electronic microstat (eTRON M; JUMO Mess- und Regelgeräte, Vienna, Austria). The water is transported from the crusher into the heated (120°C; 600 W finned strip heater; Watlow) gas-interface housing, where it is trapped in a cryo-focusing cell (see below). Another electronic microstat controls the temperature in the gas-interface housing. The latter is mounted directly on the top panel of the thermal combustion/elemental analyzer (TC/EA) unit (Thermo Fisher Scientific, Bremen, Germany), so that the inlet port of the TC/EA high-temperature conversion reactor is inside the heated zone. The purpose of this arrangement is to ensure that there are no cold spots on the sample transfer line where water could be trapped or retarded.

A high-temperature four-port two-position valve (Valco 2C4UWT; VICI AG International, Schenkon, Switzerland) is placed in the sample transfer line between the cryo-focusing cell and the inlet port of the TC/EA reactor. The valve directs the He flow either to the TC/EA or to vent. In the 'vent' position, the TC/EA reactor is isolated from the sample transfer line, so that the crusher can be removed (e.g., for sample change) and purged. During that time He flow through the TC/EA reactor is maintained due to its reverse-flow configuration (see below).

Molecular hydrogen and carbon monoxide evolved from water through reaction with glassy carbon at 1400°C in the TC/EA reactor are separated in a 5 Å packed chromatographic column and admitted, via a ConFlow II interface (Thermo Fisher Scientific), into a Delta V Advantage IRMS instrument (Thermo Fisher Scientific). Hydrogen is analyzed first, and, following a peak jump, the oxygen isotopic composition of carbon monoxide is determined subsequently.

### Crusher

The analysis of fluid inclusions is a bulk technique whereby many inclusions from relatively large fragments of a mineral specimen are released to provide sufficient water for IRMS analysis. By decreasing the sample size the discriminatory power of the analysis is obviously increased, which is important, e.g., in paleoenvironmental studies. The efficiency of crushing is therefore of paramount importance.

The crusher consists of a basal part, an upper part, and a piston (Fig. 2). Two types of the working elements (i.e., elements between which the sample is crushed) were manufactured, one made of leuco-sapphire for hard minerals (e.g., quartz, topaz), and a second one made of hardened steel

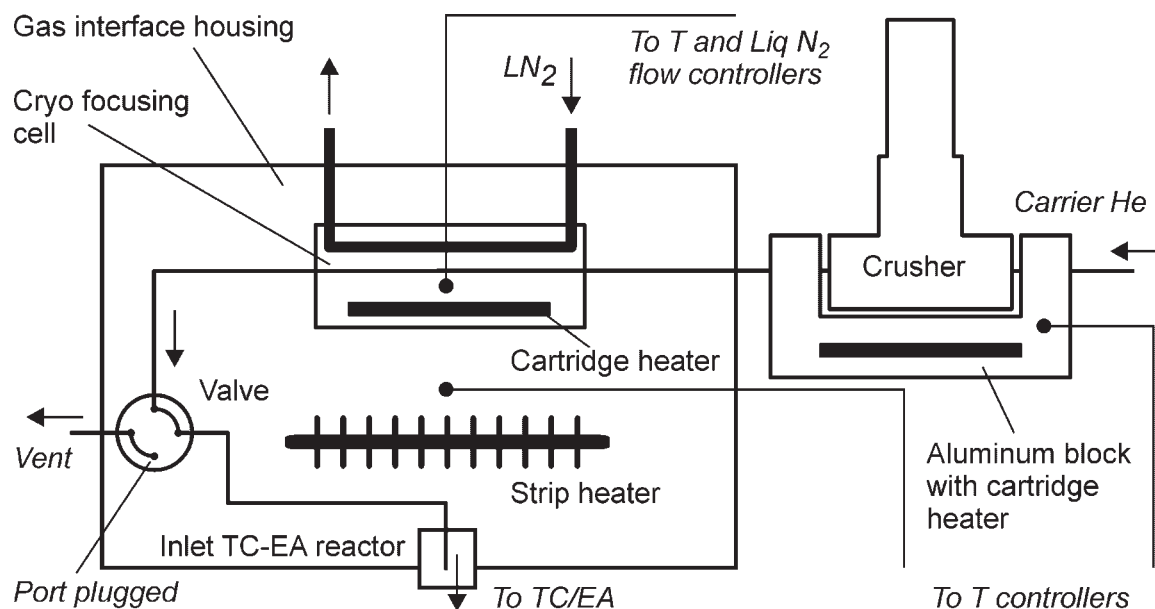

**Figure 1.** Setup of the fluid-inclusion extraction line. Purified He carrier gas enters the crusher, which is placed in an aluminium block heater. Water released by crushing is transported into the cryo-focusing cell mounted inside a heated gas-interface housing. The high-temperature four-port two-way valve directs the gas flow either to vent or to the inlet port of the high-temperature conversion unit. The temperature in the aluminium heater block and the interface housing is controlled by two microstats (lines with dots indicate temperature sensors).

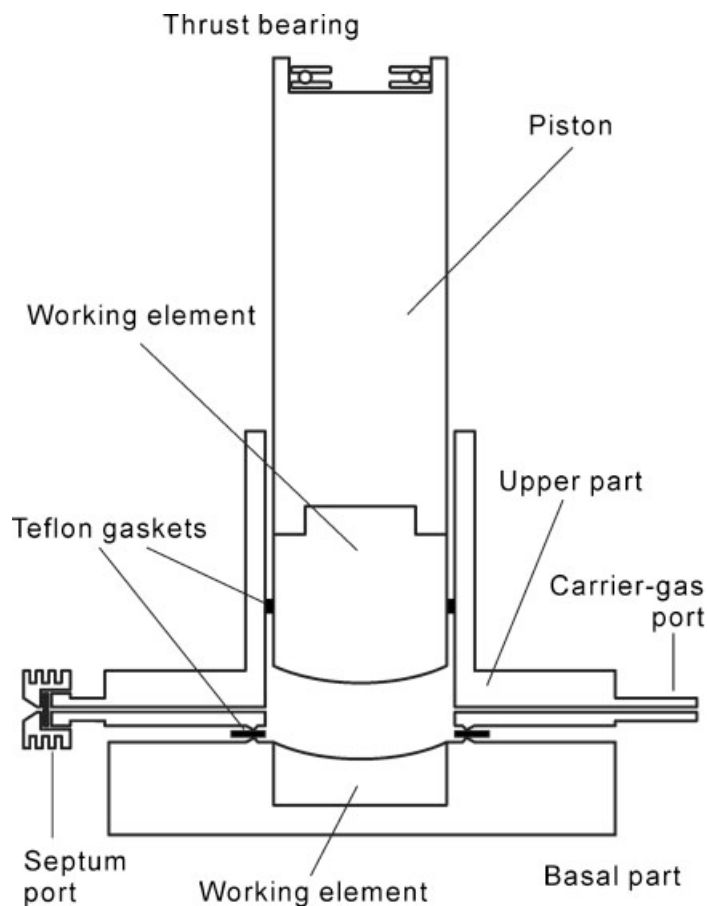

**Figure 2.** Schematic drawing and photograph of the assembled crusher. Working elements are made of leuco-sapphire (for samples with high hardness) or hardened steel. For graphical simplicity only one of the two carrier-gas ports is shown.

for soft samples (e.g., calcite, fluorite). The upper and lower elements have matching concave and convex working surfaces (Fig. 2). The perfect match between these surfaces allows crushing of even very small samples (i.e., individual grains of mm to sub-mm size). The surfaces are either rough (600 grit; sapphire) or electro-polished (steel). The lateral surfaces of both types of the upper working element are polished, which is necessary for a gas-tight contact with the upper part of the crusher (via a Teflon gasket). The upper working element is mounted coaxially on the piston and the lower working element is press-fitted into the basal part of the crusher. The basal and the upper parts of the crusher have a conflat flange connection (Teflon gasket). All wetted surfaces of the crushing cell are polished to diminish adsorption of water.

The carrier gas is admitted in and out of the crusher through two ports equipped with Swagelok Ultra-Torr<sup>®</sup> connectors (VAUST Ventile & Fittings, Gablitz, Austria), allowing easy connection and disconnection of the tubing. The cell is equipped with a septum port through which reference water can be injected using a 0.5  $\mu\text{L}$  syringe. The cap of the septum port has a finned design to enhance heat removal. Several hundreds of injections can typically be made and the standard 11.5 mm diameter septum can be easily exchanged. BTO X-145 septa (Thermo Fisher Scientific) gave the best results in terms of longevity.

The assembled crusher is installed in an aluminum block heater, mounted on a frame together with a small (length = 7 cm; diameter = 3.5 cm) hydraulic ram. The ram is connected to the piston through a thrust ball bearing which allows axial rotation of the piston. The rotation, done manually, allows trituration of the sample in addition to compression crushing. The current design allows crushing of samples ranging in sizes from individual sub-mm-sized grains up to ca. 1  $\text{cm}^3$ .

The efficiency of crushing was assessed through multiple crushes of calcite samples of different weight (Fig. 3). Samples smaller than ca. 0.5 g are crushed to fine powder (<250  $\mu\text{m}$ ) almost quantitatively (>95%). The efficiency of crushing of larger samples (up to 2.5 g) depends on the type (or, rather, the finish of the surface) of the working elements: the yield of the <250  $\mu\text{m}$  fraction is 25 to 40% for the hardened-steel working element which has polished working surfaces and 40 to 75% for the sapphire working element with rough surfaces. Although the efficiency of crushing of other minerals has not been tested systematically, from preliminary results it appears to be good. For instance, several small samples of quartz (ca. 0.2 g) were crushed quantitatively (>95%) in the crusher with the sapphire working element.

The minimum amount of water needed for precise stable isotope analyses using our setup is ca. 0.1–0.2  $\mu\text{L}$ . For

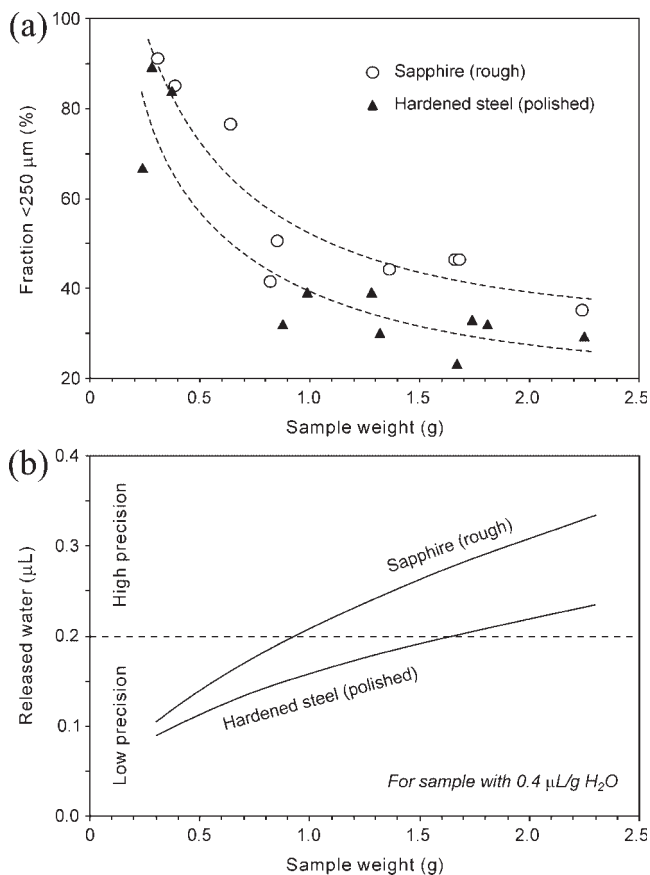

**Figure 3.** Tests showing the efficiency of the crusher. (a) Percentage of sample crushed to  $<250\ \mu\text{m}$  as a function of the initial sample weight and of the type of working elements. (b) Relationship between sample weight and the amount of water released by crushing from a hypothetical sample containing  $0.4\ \mu\text{L/g}$  of water. Dashed line indicates lower limit of precise analyses.

samples containing ca.  $0.25\ \mu\text{L H}_2\text{O}$  per gram of mineral the sapphire working element outperforms the steel model. The latter performs satisfactorily at water contents exceeding  $0.35\ \mu\text{L/g}$ .

### Cryo-focusing cell

The water vapor is transported by the carrier gas from the crusher to the cryo-focusing cell (SmartCryo; Humble Instruments & Services, Shenandoah, TX, USA), which can either be cooled down to cryogenic temperatures by flow of pressurized liquid  $\text{N}_2$  or flash-heated. The cell is mounted inside the heated-gas transfer housing and is thermally insulated from the latter. The tube of the gas transfer line (o.d.  $1.62\ \text{mm}$ , i.d.  $1.06\ \text{mm}$ ) passes through the SmartCryo cell, making a good thermal contact with it. As the temperature of the cell is lowered, the water vapor is frozen inside a ca.  $25\ \text{mm}$  long part of the tube. Upon completion of cryo-focusing (5 min) the cell is flash-heated (at a rate of  $3600^\circ\text{C}/\text{min}$ ) to  $300^\circ\text{C}$  by means of the built-in cartridge heater. The fast heating ensures that water arrives in the TC/EA high-temperature reactor as a single pulse. The parameters of the cell operation (i.e., cooling temperature, heating temperature, and heating rate) are controlled by

means of proprietary computer software (Humble Instruments & Services).

The original SmartCryo cell is designed for gas chromatographic (GC) systems with typical carrier-gas flow rates of  $4\text{--}5\ \text{mL}/\text{min}$ . In contrast, the recommended flow rate through the TC/EA reactor is much higher ( $90\text{--}110\ \text{mL}/\text{min}$ ). These flow rates translate into significantly greater linear velocities in the gas transfer line (ca.  $0.17\text{--}0.21\ \text{m/s}$  as opposed to ca.  $0.008\text{--}0.009\ \text{m/s}$  in GC systems) and much less time available for the freeze-out of water vapor entrained in the He stream. At typical GC flow rates the carrier He traverses the SmartCryo cell in  $2.5\text{--}3.0\ \text{s}$ , while at TC/EA flow rates this time is less than  $0.2\ \text{s}$  (the calculations were made for a tube with an i.d. of  $1.06\ \text{mm}$ ). In order to ensure quantitative freezing of water under these higher flow rates (a) the surface available for freezing was increased using fragments of silver wire placed inside the tube of the SmartCryo cell, and (b) freezing was performed at low temperatures ( $-150^\circ\text{C}$ ). The quantitative character of water freezing was ascertained by monitoring the  $m/z\ 2$  ion current during injections of water into the line.

The use of such low temperatures for freezing-out water entails the danger of co-freezing  $\text{CO}_2$ , which might be present in inclusions; being reduced in the TC/EA high-temperature reactor such  $\text{CO}_2$  could interfere with water analyses. In order to ascertain that no co-freezing of  $\text{CO}_2$  takes place, gaseous  $\text{CO}_2$  and  $\text{CO}_2$ -rich water were injected into the line. The subsequent gradual temperature increase of the cryo-focusing cell to  $-50^\circ\text{C}$  did not result in any discernible increase of the  $m/z\ 28$  ion current, which would be expected if frozen  $\text{CO}_2$  was released.

### TC/EA reactor

It has been shown that reversing the flow in the high-temperature reactor significantly improves the performance of the reactor and reduces memory effects.<sup>3</sup> Accordingly, the reactor of our TC/EA unit was modified by installing a bottom connector (IVA-Analysentechnik, Düsseldorf, Germany) and re-arranging the carrier gas plumbing system. Instead of a glassy carbon tube with a  $2\ \text{mm}$  hole on one end as recommended by Gehre *et al.*,<sup>3</sup> we use a 'regular' glassy carbon tube with a small electro-polished stainless-steel insert placed at its top. The stainless-steel tube of the sample transfer line passes through a  $2\ \text{mm}$  diameter hole in the insert. The end of the tube is positioned slightly below the bottom of the insert. The small gap between the tube and the insert ( $1.13\ \text{mm}^2$ ) ensures a high linear velocity of the carrier gas entering the glassy carbon tube (ca.  $0.13\ \text{m/s}$  at a flow rate of  $90\ \text{mL}/\text{min}$ ). This prevents sample water vapor from coming in contact with surfaces other than glassy carbon (e.g., the stainless-steel insert or the  $\text{Al}_2\text{O}_3$  outer tube of the reactor). Such contacts are a known cause of memory effects.

### Anti-adsorption measures

Water is a polar molecule, and therefore adsorbs readily on metal and mineral surfaces. When analyzing very small amounts of water, which is typically the case with fluid-inclusion analysis, the transfer of water from the crusher to the TC/EA reactor must be quantitative. Even tiny amounts of water lost or retarded by adsorption will affect the

measured isotope values. As was shown by Dennis *et al.*<sup>6</sup> adsorption was the most likely reason for unsuccessful early attempts using crushing to extract fluid-inclusion water for stable isotope studies. In our design several steps were taken to minimize adsorption in the line.

#### Minimization of surface

The crusher and the line were designed to optimize the balance between the volume (which must be sufficient to allow crushing of cm<sup>3</sup>-sized samples) and inner surface (which should be kept at a minimum). The compromise is a crusher with an internal surface of ca. 26 cm<sup>2</sup>. To minimize the length of the sample transfer line the latter was mounted directly on the top of the TC/EA unit. This resulted in a total inner surface of the sample transfer tube of ca. 12 cm<sup>2</sup>, bringing the total wetted surface of the line to ca. 38 cm<sup>2</sup>.

#### Surface polishing and passivation

All wetted surfaces of the crusher are polished and/or electro-polished. The surfaces of the stainless-steel tubes and fittings in the sample transfer line are passivated with Siltec<sup>®</sup>/Sulfinert<sup>®</sup> coating (SilcoTek, Bellefonte, PA, USA) in order to facilitate the removal of adsorbed moisture and shorten the times necessary to reach the background values of the *m/z* 2 ion current.

#### Heating

Dennis *et al.*<sup>6</sup> demonstrated that the adsorption of fluid-inclusion water on the freshly crushed calcite (crushing *in vacuo*) leads to significant isotopic fractionation, and recommended removing water at elevated temperatures (ca. 150°C). Vonhof *et al.*<sup>4</sup> heated their crusher to 130°C. We found that a temperature of 110 to 120°C give satisfactory results. Accordingly, the working zone of the crusher and the entire sample transfer line are kept at 120°C. There are no cold spots between the crushing cell and the inlet of the TC/EA reactor, and water is at all times in the gaseous state (except for the brief time of collection in the cryo-focusing cell). Negligible adsorption on the crushed calcite was ascertained by injecting reference water both into the empty crusher and into the crusher containing freshly crushed calcite. Although the time required for the *m/z* 2 background signal to reach stable low values increased by a factor of 2–3 for injections involving crushed calcite (which suggests that crushing creates additional sites of adsorption), no change in measured isotope values was observed.

Fluid inclusions are isochoric systems, whose pressure is controlled by the temperature. The internal pressure in a single-phase aqueous inclusion increases very rapidly with increasing temperature. Theoretically, in an inclusion trapped at 10°C at atmospheric pressure (e.g., in a speleothem) the internal pressure upon heating to 100°C will reach several kilobars; consequently, such inclusions should be expected to burst open (decrepitate) and release their water content even upon slight overheating. Our experience, however, is that fluid inclusions in calcite withstand significant overheating, apparently because of reversible and irreversible elastic deformation (stretching). Nevertheless, heating a mineral which contains single-phase inclusions to high temperatures may lead to some loss of fluid-inclusion water (Fig. 4). For

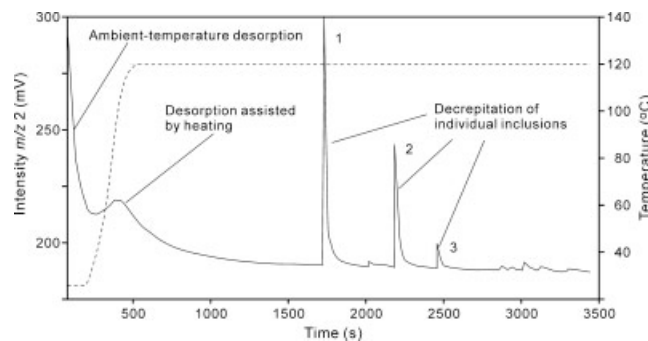

**Figure 4.** Loss of water during heating of calcite sample containing single-phase aqueous inclusions. The carrier gas passes through the crusher loaded with a sample and the *m/z* 2 ion current intensity is monitored as the temperature in the crusher is increased to 120°C (dashed line). Smooth bell-shaped peak corresponds to removal of the adsorbed water. Numbered sharp peaks on the trace correspond to decrepitation of individual inclusions with sizes (assuming a cubic geometry) of 130 μm (1), 95 μm (2), and 60 μm (3). The total amount of water lost from these three inclusions is ca. 0.03 μL. This sample shows a relatively large loss of fluid inclusion water (6.7%). For most other samples the loss was smaller.

this reason we prefer to keep the heating temperature of the crusher at a minimum value. It is also advisable to monitor the *m/z* 2 trace when heating and flushing the loaded crusher in order to assess what fraction of fluid inclusion water could be lost from the sample at this preparatory stage.

#### Off-line crusher preparation facility

In order to improve the throughput of our setup, we complemented the analytical line with the off-line crusher preparation facility. The latter consists of the two stand-alone heater blocks and a flushing system. While one crusher is connected to the line for analysis, three other loaded crushers are heated and flushed. This allows the removal of adsorbed water prior to analysis and serves to speed up the entire preparation process.

### OPERATION OF THE LINE

#### Memory effect, condition effect, and line conditioning

Wang and Sessions<sup>7</sup> use the term 'memory' to indicate any situation in which the isotopic composition of a given chromatographic peak affects that of the following peaks, regardless of its mechanism. This typically occurs when measuring samples of significantly different isotope values. Memory effects were reported from water analyses using the high-temperature conversion of water on glassy carbon. For TC/EA reactors converted into the reverse flow configuration the effect was found to be relatively small, 1–2% of the difference between the isotope values of the samples.<sup>3</sup> Our observations are consistent with this finding.

Another important issue is what can be called the 'condition effect'. We observed that the first analyses carried

out after a period of flushing of the line always produce incorrect results, even if isotopically identical water was analyzed before the flushing. This effect shows a general dependency on the isotopic composition of the sample: it was found to be negative (–6 to –3‰) for deuterium-enriched water ( $\delta D = -10.2\text{‰}$  VSMOW) and positive for deuterium-depleted waters (1 to 6‰ for water with  $\delta D = -97\text{‰}$ ; 9 to 10‰ for water with  $\delta D = -237\text{‰}$ ). Quantitatively similar effects are observed when water is injected into the crusher and transported by the sample transfer line, and when water is injected directly into the TC/EA high-temperature reactor through a septum port. This indicates that the primary source of the condition effect is not the fluid-inclusion line but the reactor, probably as a result of adsorption of hydrogen on the initially vacant sites of carbon in the TC/EA reactor.<sup>7</sup> The larger the amount of vacant sites (which depends on the duration of flushing) and the smaller the amount of hydrogen (i.e., of water arriving in the reactor) the greater the proportion of hydrogen removed by adsorption, and the more pronounced the isotopic fractionation (condition) effect. In contrast, when the adsorption sites are 'saturated' with hydrogen, the system is governed by the adsorption-desorption process. In such a 'hydrogen-saturated' reactor, the isotopic composition of the sample water can be appreciably altered only if the adsorbed hydrogen has a strongly different isotopic composition (i.e., memory effect).

In conventional CF water analyses the memory and the condition effects are mitigated by injecting multiple aliquots of the sample and disregarding the results from the first two or three injections.<sup>7</sup> This approach is not directly applicable to fluid-inclusion analyses, as only one sample can be crushed at a time, and the amount of material that can be crushed is typically limited. In order to reduce the unwanted memory and condition effects we therefore condition the line prior to crushing using a similar approach as outlined by Vonhof *et al.*,<sup>4</sup> i.e., by three injections (ca. 0.4  $\mu\text{L}$  each) of water of an isotopic composition similar to that expected for the sample. We have found that, if the conditioning water is within  $\pm 20\text{‰}$   $\delta D$  of the sample composition, the cumulative memory effect does not exceed other sources of analytical error.

### Dual analysis

Water released from fluid inclusions is analyzed for both  $\delta D$  and  $\delta^{18}\text{O}$ . Molecular hydrogen and carbon monoxide formed in the high-temperature reactor according to the reaction  $\text{H}_2\text{O} + \text{C} = \text{H}_2 + \text{CO}$  are separated in a 5 Å packed GC column. In the dual measurement procedure the hydrogen peak is measured first, after which the software stops the HD acquisition, the magnet jumps to the CO configuration, and the CO peak is measured.

### Normalization

Measured raw (instrument-scale) isotopic values must be converted into the VSMOW scale. This is done by measuring laboratory reference waters previously calibrated against VSMOW and SLAP. The reference waters are selected so that their isotope values bracket those of the measured fluid-

inclusion waters. In order to reproduce the conditions during the analysis of fluid-inclusion water, the reference water is injected into the crusher containing crushed calcite and collected in the cryo-focusing cell, after which it is admitted into the TC/EA.

The measured  $\delta D$  and  $\delta^{18}\text{O}$  values vary according to the amount of water. To account for this effect different amounts of reference water are injected, which bracket the amounts of water released from inclusions (typically between 0.2 and 0.4  $\mu\text{L}$ ). Approximately five injections are made to obtain a regression line for each of the reference waters. The linearity-corrected isotope values are then converted into the VSMOW scale by linear regression equations obtained by relating the measured (instrument scale) to the accepted (VSMOW) values of reference waters. The conversion calculations are made individually for each analysis, using the amount of water released from inclusions of a given crush.

When the amount of analyzed water is sufficiently large (i.e., the  $m/z$  2 peak area is greater than ca. 20 Vs, corresponding to ca. 0.2  $\mu\text{L}$  or 0.11  $\mu\text{mol}$   $\text{H}_2\text{O}$ ), the values on a given day plot on a well-defined regression line (typical  $R^2 > 0.8$ ; Fig. 5). The linearity correction for each crushed sample is made using the data for that day. For smaller amounts of water this linear relationship no longer applies. Although the data still plot within a relatively narrow band (Fig. 5) the slope is steeper and the scatter increases resulting in less precise measurements. A generalized function approximating the injection data from several

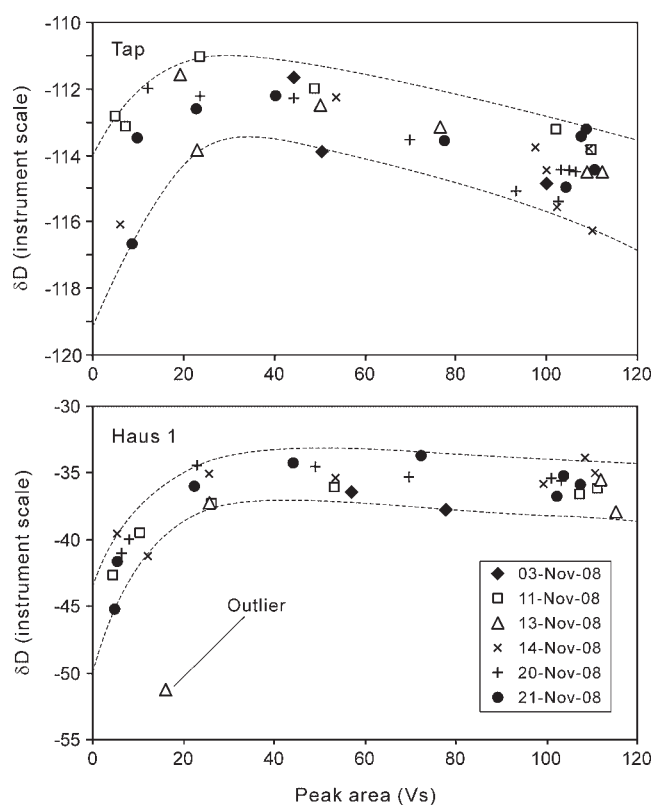

**Figure 5.** Hydrogen isotope values (instrument-scale) measured for different amounts of the two reference waters injected into the crusher on different dates.

days (Fig. 5) is used for data reduction of such water-poor samples.

### Protocol

As a matter of general policy, any sample is analyzed in duplicate or triplicate. The typical daily sequence of tasks includes:

#### *Preparation of the mass spectrometer*

Checking backgrounds, determination of the  $H_3^+$  correction factor, zero-enrichment tests for  $H_2$  and  $CO$ , and peak jump calibration.

#### *Preparation and conditioning of the line*

The first loaded crusher is connected to the line, heated and flushed. Three injections,  $0.4 \mu\text{L}$  each, at 4–5 min intervals are made through the crusher's septum port to condition the line. Water of isotopic composition broadly similar to that expected for the sample ( $\pm 20\%$   $\delta\text{D}$ ) is used. After the last injection the  $m/z$  2 ion current intensity trace is monitored until it decreases to typical background values (mostly within 15–20 min).

#### *Preparation of crushers*

Three more crushers are loaded with samples, assembled, placed in the heated blocks, and connected to the auxiliary flushing line.

#### *Crushing*

The SmartCryo is started and the temperature in the cryo-focusing cell is lowered to  $-150^\circ\text{C}$ . The sample is crushed and the released water is collected for 3 min. Acquisition is started and after approximately 2 min a command is sent from the PC to the SmartCryo to heat the cell. The timing of water release from the cryo-focusing cell is optimized so that the automatic peak jump is completed prior to the arrival of the  $CO$  peak. The TC/EA is then isolated from the line by switching the two-position valve to the 'vent' position. The first crusher is replaced with the second one, removed from the off-line stand, and the procedure is repeated. As long as the expected isotopic composition of samples remains broadly similar (within  $\pm 20\%$   $\delta\text{D}$ ) no line conditioning is required between crushing steps (cf. *Preparation and conditioning of the line*).

#### *Measurements of reference water*

After crushing of several samples the last crusher (containing crushed mineral) is left connected to the line. The first reference water is injected into the line ( $3 \times \text{ca. } 0.4 \mu\text{L}$  each). These injections serve to condition the line and no measurements are taken. Once the  $m/z$  2 ion current intensity approaches typical background values the SmartCryo is started, reference water is injected into the crusher, water is collected for 3 min, released, and analysed in the same manner as in the crushing experiments. The volumes of injected water are chosen so that they bracket the range of the water released from the samples. The procedure (i.e., line

conditioning and measurements) is repeated for the second reference water.

#### *Correction and normalization*

The measured raw values are corrected for linearity and converted into the VSMOW scale.

### Precision

The precision was assessed by repeated crushing of well-characterized natural calcite samples which are used as working standards in our laboratory (Table 1). The sample SB10 is from a deep-seated, low-temperature (ca.  $30^\circ\text{C}$ ) fossil flow system at Stegbachgraben, Austria.<sup>8</sup> The inner, isotopically homogeneous part ( $\delta^{18}\text{O}_{\text{calcite}} = -15.12 \pm 0.12\%$  VPDB,  $n=7$ ) of 5–7 cm large, rhombohedral crystals was used. The second sample, OBI 85, is from a large flowstone sampled in the vicinity of Obir Cave, Austria. A distinct, approximately 8 mm thick layer of compact crystalline calcite ( $\delta^{18}\text{O}_{\text{calcite}} = -5.93 \pm 0.07\%$  VPDB,  $n=7$ ) was sampled. A series of aliquots of these two isotopically homogeneous working standards was prepared using a diamond band saw.

**Table 1.** Results of reproducibility tests of repeated analyses of fluid-inclusion water (n.m. not measured)

Date	Sample ID	$\delta^{18}\text{O}$ (‰)	Outliers ( $\delta^{18}\text{O}$ ) (‰)	$\delta\text{D}$ (‰)	Water content ( $\mu\text{L/g CaCO}_3$ )
Stegbachgraben phreatic calcite					
080225	SB10	n.m.		-103.0	n.m.
080225		n.m.		-101.4	n.m.
080225		n.m.		-100.5	n.m.
080313		n.m.		-104.0	n.m.
080313		n.m.		-102.1	n.m.
080313		n.m.		-103.5	n.m.
081202		n.m.		-103.5	n.m.
090112		n.m.		-102.0	n.m.
090112		n.m.		-102.0	n.m.
	<i>Mean</i>			-102.4	
	<i>SD</i>			1.1	
Obir Cave, flowstone					
090310	OBI85	-10.56		-71.5	0.09
090310		-10.25		-71.2	0.10
090310		-10.60		-70.4	0.11
090310		-10.64		-73.8	0.09
	<i>Mean</i>	-10.51		-71.7	0.10
	<i>SD</i>	0.17		1.5	0.01
Obir Cave, Silbersee 'pool spar'					
081211	SBS1		failed	-74.5	n.m.
081211		-10.94		-72.5	0.33
081212			-13.57	-73.9	0.21
090402		-11.18		-73.4	0.36
090402		-11.45		-74.0	0.22
	<i>Mean</i>	-11.19		-73.7	0.28
	<i>SD</i>	0.26		0.7	0.08
Obir Cave, Kristallsee 'pool spar'					
081204	OB1		-8.73	-70.1	0.56
081204		-10.37		-70.8	0.42
081205		-9.81		-69.6	0.29
081205		-9.59		-69.7	0.41
	<i>Mean</i>	-9.92		-70.0	0.42
	<i>SD</i>	0.40		0.6	0.11

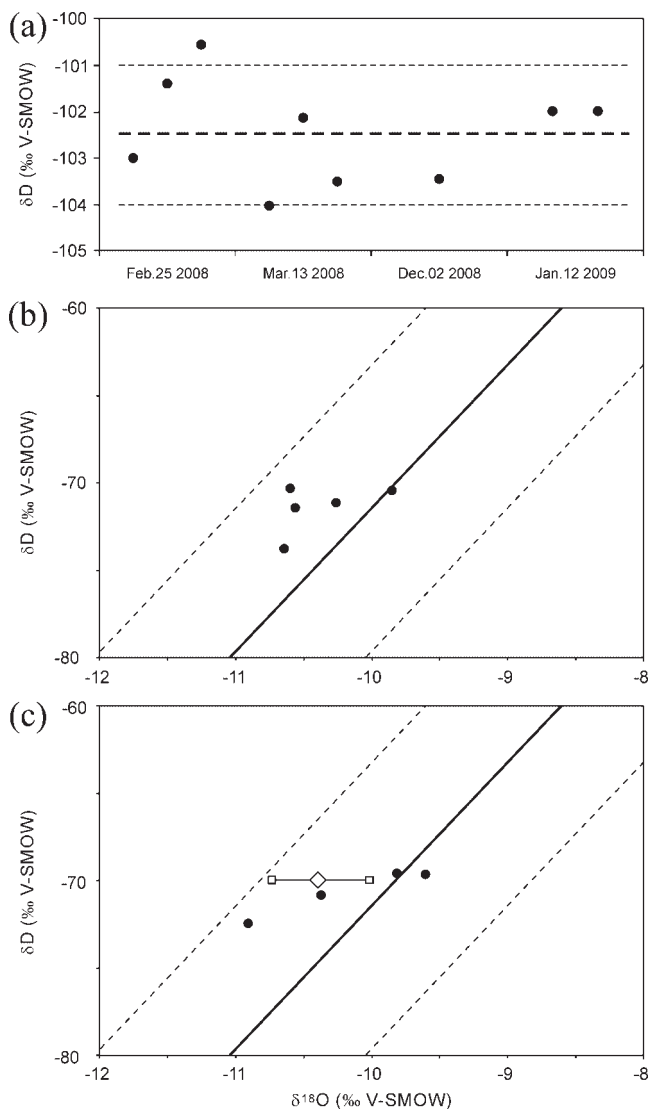

**Figure 6.** Assessing precision and accuracy of fluid-inclusion analyses. (a) Hydrogen isotope analyses of fluid-inclusion water from a low-temperature phreatic calcite (SB10) performed over a 11 month long period; bold dashed line: mean value; thin dashed lines:  $\pm 1.5\%$  interval. (b) Dual (hydrogen and oxygen) analyses of fluid-inclusion water from an individual layer of calcite flowstone (OBI85). (c) Four dual analyses of fluid-inclusion water from 'pool spar' calcite OB1 (large dots); diamond indicates measured long-term average composition of the parent water, squares connected by a tie line show equilibrium values of parent water calculated from measured  $\delta^{18}O$  calcite and temperature values using fractionation coefficients of Friedman and O'Neil<sup>9</sup> and Coplen<sup>10</sup> (left and right, respectively). Solid lines in (b) and (c) correspond to the local Meteoric Water Line for Austria;<sup>14</sup> dashed lines delineate a  $\pm 1\%$   $\delta^{18}O$  corridor, corresponding to the typical natural variability of meteoric waters in caves.

The  $\delta D$  value of fluid-inclusion water of SB10 was measured several times over a 1 year period (Table 1, Fig. 6(a)). The standard deviation (SD) of these measurements is 1.1‰. For the OBI 85 sample the SDs are 1.5‰ for  $\delta D$  and 0.17‰ for  $\delta^{18}O$ . Two samples of 'pool spar' from Obir

Cave (OBI and SBS1; see next section) show SDs of 0.6–0.7‰ for  $\delta D$  and 0.26–0.40‰ for  $\delta^{18}O$ . One of these samples was analyzed in two sessions 4 months apart.

It must be noted that the  $\delta^{18}O$  results for fluid-inclusion waters are typically more variable than the  $\delta D$  results. Occasionally, the  $\delta^{18}O$  measurements yield values which are unreasonable (i.e., off by several ‰; see Table 1). Such values are clear outliers; as such, they were disregarded and not included in calculations of the SD. The reason for this occasional erratic behaviour is presently not understood.

As was discussed above, the most precise results were obtained when sufficiently large amounts of water were present in these crystals ( $>ca. 0.2 \mu L$ ); in many cases reasonably good precision was also obtained on smaller samples ( $>ca. 0.1 \mu L$ ). For such samples, the precision is typically better than 1.5‰ for  $\delta D$  and 0.5‰ for  $\delta^{18}O$  ( $1\sigma$ ; see Table 1).

### Accuracy

The accuracy was assessed through analyses of fluid-inclusion water from a recently formed calcite sample for which the isotope composition of its parent water as well as the physical setting of precipitation are highly stable and well characterized. For this purpose we selected a 'pool spar' calcite from the bottom of a shallow lake in the deep part of Obir Cave (Austria, sample OBI). The topmost 2 cm of this coarsely crystalline calcite crust were sampled, probably representing growth during the past few decades. The isotopic composition of the lake water ( $\delta D_w = -70.1 \pm 0.3\%$ ,  $\delta^{18}O = -10.40 \pm 0.06\%$  VSMOW) and its temperature ( $5.2 \pm 0.2^\circ C$ ) have remained essentially stable over the 4 year long monitoring period (C. Spötl, unpublished data). The relative humidity in this cave chamber approaches 100% and thus minimizes isotope fractionation as a result of evaporation from the pool surface.

The hydrogen isotope composition measured on fluid-inclusion water in OBI matches that of the lake water ( $\delta D_{fi} = -70.0 \pm 0.6\%$ ;  $n = 4$ ) and the oxygen isotope values agree within ca. 0.5‰ ( $\delta^{18}O_{fi} = -9.92 \pm 0.40\%$ ;  $n = 4$ ). The paired  $\delta D_{fi}/\delta^{18}O_{fi}$  values plot within 1‰ ( $\delta^{18}O$ ) of the local Meteoric Water Line for Austria (Fig. 6(c)). This suggests that the fluid-inclusion water in this calcite faithfully preserves the original isotope composition of mineral-forming water and that the isotope values measured in fluid inclusions using our technique accurately reflect the values of the mineral-forming water.

Knowledge of the isotopic and physical parameters of the mineral-forming water in the Obir Lake permits us to compare results of our fluid-inclusion measurements with equilibrium calculations. The equilibrium  $\delta^{18}O_{water}$  for the Obir samples was calculated from the  $\delta^{18}O_{calcite}$  and the measured water temperature using the fractionation factors of Friedman and O'Neil<sup>9</sup> and Coplen.<sup>10</sup> The differences between the measured  $\delta^{18}O$  of the lake water and the calculated equilibrium  $\delta^{18}O$  are 0.3‰<sup>9</sup> and  $-0.4\%$ ,<sup>10</sup> respectively (Fig. 6(c)). If the equations are solved for temperature, the respective errors are  $-1.2$  and  $+1.8^\circ C$ . These calculations confirm that the Obir pool spar was deposited very close to equilibrium with the lake water.



## CONCLUSIONS

Until recently, most stable isotope analyses of water from fluid inclusions were made on analytical lines and setups which were unique in their design, and differed in their parameters and even in the physical principles of operation.<sup>11–13</sup> In our opinion the CF-IRMS method used in conjunction with the heated crushing method has the potential of becoming the method of choice. Results from the Amsterdam Vrije University group<sup>4,5</sup> and our work at Innsbruck University confirm the (relative) simplicity, robustness, and accuracy of the method. In addition this method has the benefit of allowing the analysis of both hydrogen and oxygen isotopes in a single acquisition.

We propose that the next step in the development in this field should be a concerted effort of the involved laboratories in establishing working standards for an inter-laboratory comparison. Successful completion of such an exercise would significantly increase confidence in the accuracy (and precision) of the stable isotope measurements and their acceptance by the scientific community.

## Acknowledgements

This work was supported by FWF grant no. 182070. Initial work on the preparatory design was funded by the Museo Tridentino di Scienze Naturali, Trento, Italy (NEXTEC project). The authors appreciate the constructive comments of

the three RCM reviewers, which helped to improve the manuscript.

## REFERENCES

1. Dallai L, Lucchini L, Sharp ZD. Techniques for stable isotope analysis of fluid and gaseous inclusions. In *Handbook of Stable Isotope Analytical Techniques*, de Groot P (ed). Elsevier: Amsterdam, 2004; 62–77.
2. Sharp ZD, Atudorei V, Durakiewicz T. *Chem. Geol.* 2001; **178**: 197.
3. Gehre M, Geilmann H, Richter J, Werner RA, Brand WA. *Rapid Commun. Mass Spectrom.* 2004; **18**: 2650.
4. Vonhof HB, van Breukelen MR, Postma O, Rowe PJ, Atkinson TC, Kroon D. *Rapid Commun. Mass Spectrom.* 2006; **20**: 2553.
5. van Breukelen MR, Vonhof H, Hellstrom JC, Wester WCG, Kroon D. *Earth Planet. Sci. Lett.* 2008; **275**: 54.
6. Dennis PF, Rowe PJ, Atkinson TC. *Geochim. Cosmochim. Acta* 2001; **65**: 871.
7. Wang Y, Sessions AL. *Anal. Chem.* 2008; **80**: 9162.
8. Spötl C, Dublyansky Y, Meyer M, Mangini A. *Int. J. Earth Sci.* 2009; **98**: 665.
9. Friedman I, O'Neil JR. *U. S. Geol. Surv. Prof. Paper* 1977; **440-KK**: 1–149.
10. Coplen TB. *Geochim. Cosmochim. Acta* 2007; **71**: 3948.
11. Schwarcz HP, Harmon RS, Thompson P, Ford DC. *Geochim. Cosmochim. Acta* 1976; **40**: 657.
12. Zhang R, Schwarcz HP, Ford DC, Serefiddin-Schroeder F, Beddows PA. *Geochim. Cosmochim. Acta* 2008; **72**: 1014.
13. Demény A, Siklósy Z. *Rapid Commun. Mass Spectrom.* 2008; **22**: 1329.
14. Humer G, Rank D, Trimborn P, Stichler W. *Niederschlagsisotopenmessnetz Österreich*, Monographien 52, Umweltbundesamt: Vienna, 1995.